



## Astral Heat Pumps

# INSTALLATION AND OPERATING INSTRUCTIONS



Melbourne: 03 8796 8600  
Sydney: 02 9853 2100  
Brisbane: 07 3308 5400

Gold Coast: 07 5552 2600  
Townsville: 07 4750 3100  
Adelaide: 08 8152 7600

Perth: 08 9350 2600  
sales@astralpool.com.au  
www.astralpool.com.au

A division of  
**FLUIDRA**  
The Fluidra logo graphic consists of four overlapping circles in shades of blue and green.

|

|

# CONTENTS

## **Introduction**

Introduction.....	3
Notice to Installers .....	4
Safety Rules .....	4

## **Operation**

Operating Instructions.....	4
Chemical Balance .....	5
Technical Specifications .....	6
Digital Thermostat Operation .....	7
Fault Indication .....	8

## **Maintenance**

Maintenance Instructions .....	8
Energy saving Tips .....	8
Winter Operation.....	9

## **Installation**

Flow Rates .....	10
Water Connections .....	10
Clearances .....	11
Electrical Connection.....	11
Guide to Heat Pump Noise .....	12

## **Troubleshooting**

Fault Finding and Remedies .....	16
Wiring Diagrams.....	17

## **Warranty**

Terms and Conditions .....	20
----------------------------	----

## INTRODUCTION

Congratulations on the purchase of an Astral Pool Heat Pump, Pool and Spa Heater. Proper installation and service of your new heating system and correct chemical maintenance of the water will ensure many years of service. It is equipped with features that take advantage of new technology developed exclusively by Astral Pool.

This unit can safely be connected to PVC pipe. In addition, the unit is equipped with an accurate electronic thermostat to ensure ease of use and accurate temperature control. The electronic display tells at a glance the operational status of the heater.

Your heat pump works by extracting heat from the surrounding air. The heat pump works most efficiently in warm weather. So, it is best to operate the heat pump during the warmest part of the day rather than overnight or early in the morning.

It is important to ensure an adequate supply of air and to avoid recirculation of the cooled air exiting the top of the unit. For this reason, the heat pump should not be installed in confined spaces and must have a minimum of 1500 mm clearance above it and 500 mm clearance to the sides and rear. A clearance of 1000mm is required to the front of the unit to allow access to the controls and service panel.

Although the unit is weatherproof, it is recommended some protection from the harsh effects of direct exposure to the elements be provided.

The heat pump **must** be installed outdoors on a level concrete pad.

In most circumstances where heating is required, the heat pump will need to run longer than the filtration. For the most effective heating it may be necessary to install a small pump to circulate water through the heat pump independent of the filtration system. Since the heat pump uses electricity so efficiently, it is a pity to waste electricity running an oversized pump. For this reason, the small added cost of a dedicated pump can be recouped and a great deal of energy saved over the life of the heater.

## **NOTICE TO INSTALLERS**

**Heat Pump must be located outdoors with sufficient ventilation as explained on page 10.**

This appliance must be installed by an authorized person.

This appliance must be installed in accordance with the installation instructions, the National Wiring Rules and any other relevant statutory authorities.

Refer to data plate for details of operating voltage and current.

A multi-pole isolating switch must be installed that operates in all live conductors so that it isolates the entire equipment from the supply.

Phase rotation must be checked on 3 phase units. Incorrect rotation will damage the compressor and void any warranties.

## **SAFETY RULES**

1. Spa or hot tub water temperature should never exceed 40°C.
2. Drinking of alcoholic beverages before or during spa or hot tub use can cause drowsiness which could lead to unconsciousness and subsequently result in drowning.
3. Pregnant women beware! Soaking in water above 38°C can cause foetal damage during the first three months of pregnancy.
4. Before entering the spa or hot tub, the user should check the water temperature with an accurate thermometer, spa or hot tub thermostats may be inaccurate by as much as 2°C.
5. Persons with a medical history of heart disease, circulatory problems, diabetes or blood pressure problems should obtain their physician's advice before using spas or hot tubs.
6. Persons taking medications which induce drowsiness, such as tranquilisers, antihistamines or anticoagulants, should not use spas or hot tubs. If in doubt seek medical advice.

**WARNING:** Should overheating occur or the heater fail to shut off, turn off the manual isolation switch to the appliance. Do not use this heater if any part has been under water.

## **OPERATING INSTRUCTIONS**

1. STOP! Read the safety information above.
2. Turn filtration pump or dedicated pump on. The display should indicate flow.
3. Turn on power to the Heat Pump.
4. Set thermostat to desired setting
5. If the water temperature is below the set temperature, the fan will start. The compressor will start in a few minutes. (Set by the compressor delay timer)
6. If the appliance will not operate, follow instructions 2 to 4 above ensuring the thermostat is set to a higher temperature than the indicated water temperature. If the appliance still does not operate, call your service technician.

During operation in weather below about 10 deg, ice may appear on the evaporator coil. An automatic defrost mode will initiate. During a defrost cycle the compressor will continue to run however the direction of the gas in the system is reversed so that the evaporator coil is heated. A 'whoosh' may be heard as this occurs. The fan will continue to run in order to melt the accumulated ice. When the evaporator temperature rises sufficiently to allow continued operation, the compressor will restart in heating mode.

During this heated defrost mode, there may be visible water vapour in the airstream. This is normal during cold weather.

## CHEMICAL BALANCE

It is imperative that correct chemical balance be maintained in your pool and spa water, otherwise corrosion of your heater may occur. **Corrosion due to chemically imbalanced water or excessive sanitiser is detectable and will void warranty.** Your local pool shop specialist or spa retailer can advise correct chemical balance. Your water should be checked and maintained regularly by a pool water professional. As a guide the following parameters may be used.

pH	7.6 to 7.8
Total Alkalinity	80 to 120 ppm
Calcium Hardness	150 ppm

You should test your water chemical balance at least on a weekly basis.

Excessive sanitiser can damage your heater. Chlorine should not exceed 3 ppm and bromine should not exceed 5 ppm. Salt chlorinators, especially when used on spa pools or indoor or covered pools, can easily produce excessive chlorine levels which will damage the heater internals.

# TECHNICAL SPECIFICATIONS

Model	ASTRAL	BPM400A	BPM600A	BPM700A	BPM800A	BPT900A
HEATING CAPACITY	BTU/H	29000	43000	58000	72000	85000
	W	8500	13000	17000	21000	25000
HEATING POWER INPUT	W	1700	2600	3500	4500	5500
EFFICIENCY	COP	5.0	5.0	4.9	4.7	4.6
HEATING NOMINAL CURRENT	A	8.3	11	14.7	19.3	8.8
VOLTAGE/FREQUENCY	V/PH/Hz	240/1/50	240/1/50	240/1/50	240/1/50	415/3/50
COMPRESSOR UNIT		1	1	1	1	1
COMPRESSOR TYPE		ROTARY	ROTARY	SCROLL	SCROLL	SCROLL
HEAT EXCHANGER	<i>PVC HERMETIC WATER BARREL WITH SPIRAL SOFT TITANIUM PIPES INSIDE</i>					
REFRIGERANT	<i>R407C</i>					
BLOWER QUANTITY		1	1	1	1	1
FAN POWER INPUT	W	45	60	120	200	200
FAN ROTATE SPEED	RPM	850	850	850	850	850
BLOWER STYLE	<i>LATERAL-BLOW</i>					
NOISE LEVEL	dB(A)	≤51	≤58	≤58	≤58	≤58
WATER CONNECTION	mm	50	50	50	50	50
WATER FLOW	m <sup>3</sup> /h	≥5.0	≥7.5	≥8.0	≥9.0	≥10.0
WATER PRESSURE LOSS	kPa	10	12	12	12	12
NET DIMENSION	mm	860×310×920	860×310×920	950×340×1300	950×340×1300	950×340×1300
GROSS DIMENSION	mm	930×430×1080	930×430×1080	1030×460×1450	1030×460×1450	1030×460×1450
WOODEN PLATE	mm	920×420×100	920×420×100	1020×450×100	1020×450×100	1020×450×100
PACKING		CARTON	CARTON	CARTON	CARTON	CARTON
NET WEIGHT	Kg	70	75	97	110	115
GROSS WEIGHT	Kg	85	90	117	140	145
Starting Current	A	30	40	40	40	40
Fuse gauge	A	20	32	40	60	20
Supply gauge	mm <sup>2</sup>	3×2.5	3×2.5	3×4.0	3×4.0	5×2.5

## DIGITAL THERMOSTAT OPERATION



### **DESCRIPTION**

The sophisticated digital thermostat provides temperature read out, set point temperature and operating status of the heater. The electronic display indicates the operational status of the heater and any fault conditions.

### **TEMPERATURE DISPLAY**

The temperature display indicates water temperature in the inlet of the heater. Therefore the pump must be operating for an accurate pool or spa water temperature to be displayed.

Comfortable pool temperature is between 26°C and 30°C. Normal spa temperature is between 36°C and 38°C. To select your desired temperature;



- Press the set key for at least 2 seconds, and enter the temperature adjustment
- Change the setting by using the i or g key (i to add or g to subtract) by 0.1 degrees. If pressed and held for more than 0.5 seconds, the increase or decrease will move quicker.
- After completing adjustment, press the set key again and then leave the set parameters mode.
- If you wish to cancel your adjustment and exit the operation, press the M button.

The thermostat can be set to temperatures between 10°C and 40°C. It also incorporates several safety features including a 45°C high limit function to prevent overheating of the pool or spa. On simultaneous shut down of the circulating pump and heater, the water within the heater may exceed 45°C for a short period. If the pump and heater are restarted during this period, the thermostat will go into a standby mode and prevent the heater from operating until the temperature within the heater has dropped below the set temperature.



## FAULT INDICATION

Under fault conditions the thermostat display will indicate a set of alpha numeric symbols to indicate the status of the heater. The meaning of each symbol and action to be taken are listed as follows:

SYMBOL	DENOMINATION	LIGHT	BLINKING
	Temp Adjustment	Temp adjustment mode	-
	Heating	Heating	Ready to heat, delayed power on mode for compressor protection
	Defrost	Defrost	Drip or delayed power on mode for compressor protection
(( • ))	Alarm	-	Alarm mode

## MAINTENANCE

It is recommended that you check the following at least every six months and at the beginning of every swimming season.

1. Make sure there are no obstructions to the flow of air to or from the appliance.
2. Examine the evaporator coil and fan grille. Check that debris such as leaves has not accumulated on the inside or outside of the heater. If the evaporator coil is restricted, the heater will not perform at optimum efficiency. The interior of the heater should be cleaned by a qualified service technician.
3. Keep the heater area clear and free of combustibles and flammable liquids. Chlorine should not be stored in the vicinity of the heater. Chlorine vapour, when drawn through a heater, can rapidly cause corrosion of working parts and exterior panels.
4. Keep the heater area free from garden refuse and debris. This will help prevent insects nesting in the unit and ensure extended life and reliability of your heater.

## ENERGY SAVING TIPS

1. If possible, keep pool or spa covered when not in use. This will not only cut heating costs, but will also keep dirt and debris from settling in the pool and conserve chemicals.
2. Reduce pool thermostat setting to 28°C or lower. This is accepted as a comfortable and healthy swimming temperature.
3. Use an accurate thermometer.
4. Set timeclock to start filtration and circulation system no earlier than daybreak. The pool loses less heat at this time and the heat pump operates more efficiently during the warmer times of the day.
5. If your filtration pump is large, consider installing a small pump for circulating water through the heat pump.
6. For pools that are only used on weekends, it is not necessary to leave the thermostat set at normal swimming temperature. During the week, lower it by an amount that can easily be achieved in one day (generally 2°C to 5°C).
7. During the winter or while on vacation, turn the heater off.
8. Set up a regular program of preventative maintenance for the heater each new swimming season.

## **WINTER OPERATION**

If the pool won't be used for a month or more, turn the heater off at the main isolating switch. For areas where there is no danger of freezing, water should circulate through your heater all year long even though you are not heating your pool.

Where freezing is possible, it is necessary to drain the water from the heater. This may be done by loosening the inlet or outlet barrel union. If the heater is below water level, isolate it from the pool first by closing shut off valves before and after the heater.

**CAUTION:** If the heater has been drained for freezing conditions, do not turn on until the system is circulating water.

## INSTALLATION

THIS APPLIANCE MUST BE INSTALLED BY AN AUTHORISED PERSON. Refer to heater data plate for specifications of operating voltage and current and water pressure.

This appliance must be installed in accordance with local regulations and the National Wiring Rules.

A multi-pole isolating switch must be installed that operates in all live conductors so that it isolates the entire equipment from the supply.

### **FLOW RATES**

The Astral Pool Heater requires a flow rate of approx 150 to 550 litres per minute. For flow rates in excess of 250 litres per minute, an external by-pass valve must be fitted. When setting up the unit, the water balancing valve should be adjusted while the heat pump is operating. Using the gauge fitted on the front of the unit, adjust water flow until reading is approximately 1.5MPa. With the unit turned off, the gauge should settle at approximately 0.8MPa. If these readings are not achieved, please contact Astral Pool service.

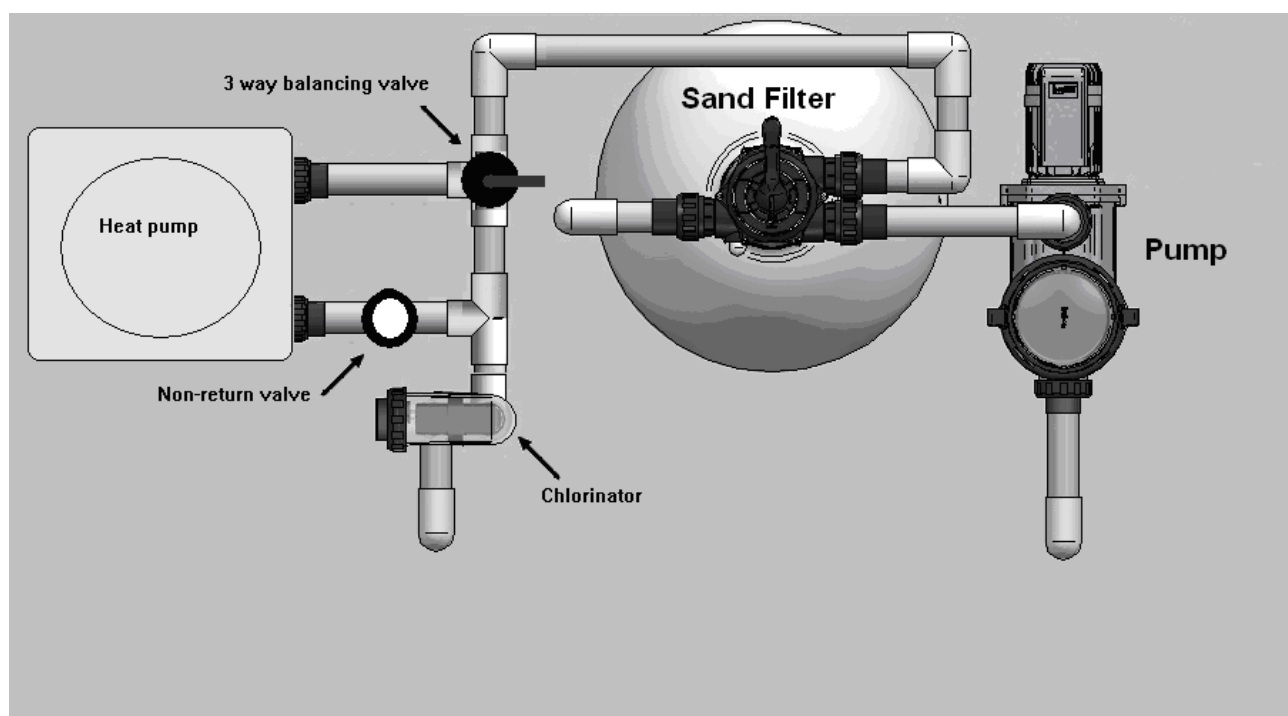

### **WATER CONNECTIONS**

Where the heat pump is installed in the filtration circuit, the heater should always be installed after the pump and filter. The water connections are located on the right hand side of the heater. The inlet and outlet are clearly marked. Water connections supplied are for 50mm PVC glue in plumbing.

**All** automatic sanitising devices must be installed after the heater and in such a way that the sanitiser cannot enter the heater without first mixing with the water in the pool or spa. Sanitisers that are connected prior to the heater will void heater warranty.

The Astral Pool Heat Pump Pool Heater is only suitable for outdoor installation.

## CLEARANCES

The heater must be installed at least 500 mm from any obstruction to airflow at the rear and sides.

There must be at least 1500mm clearance above the heater.

A minimum of 1000mm clearance should be provided at the front of the heater to permit access to the controls and service panel.

**Heater must be installed on a solid, level base.**

## ELECTRICAL CONNECTION

The heater must be installed by a licensed electrician. The heater incorporates a 240/24 VAC transformer which supplies power to the control circuit. All pool or spa equipment connected to mains power should be protected by an RCD circuit breaker.

Refer to heater data plate for specifications of operating voltage and current.

This appliance must be installed in accordance with local regulations and the National Wiring Rules.

A multi-pole isolating switch must be installed that operates in all live conductors so that it isolates the entire equipment from the supply.

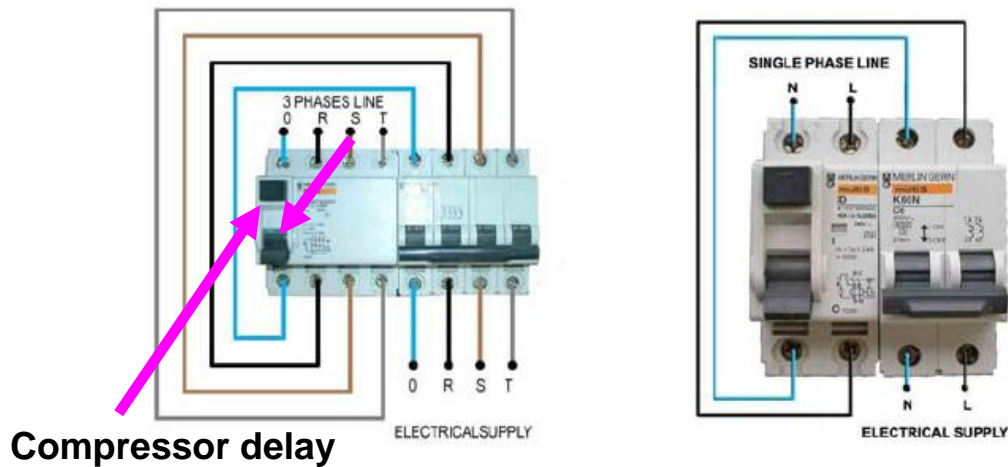

<b>ELECTRICAL DATA</b>	BPM400	BPM600	BPM700	BPM800	BPT900
Voltage(V)	240II	240II	240II	240II	415III
Section(mm <sup>2</sup> ) PURIFICATION PUMP	1,5	1,5	1,5	1,5	1,5
Section(mm <sup>2</sup> ) POWER	2,5	2,5	4	4	2,5
N <sup>o</sup> . of wires	1+N+T	1+N+T	1+N+T	1+N+T	3+N+T

## GUIDE TO HEAT PUMP NOISE

Heat Pumps are designed for slow heat up times and maintenance heating. The limitation of power supply in nearly all residential homes means that a Heat Pump's maximum size for most homes is about 6 hp. A unit of this size will typically generate around 25 kW of pool heating at maximum efficiency. For most swimming pools, this means the Heat Pump will operate for 2 or 3 days continuously for the initial heat up period and then between 12 and 24 hours each day to maintain the swimming pool temperature.

Heat Pumps are very similar to air conditioners. An evaporator fan and compressor operate during their "on" time and as the "on" time can be 12 to 24 hours per day, care must be taken to locate the Heat Pump so that the noise produced during its operation does not interfere with sensitive areas - not only in your own home but in your neighbour's home.

Each State in Australia has municipal, state and EPA laws which govern the installation and operation of outdoor appliances in residential areas. In general, noise from an appliance such as a Heat Pump must not unreasonably interfere with the health, welfare, convenience, comfort and amenity of any person having regard to the nature and duration of the noise emission and the time of day at which the noise is emitted.

Criteria for noise emissions generally take into account back ground noise at the time of day, but the most stringent criteria applies at night – and take into account, the Heat Pump will most likely need to operate at night during cooler months of the year to maintain the pool temperature.

This guide provides an estimate only and should not be taken as definite advice on the location and installation of your Heat Pump. Should any doubt exist, seek advice from an Acoustical Consultant which can be found in the Yellow Pages.

The ASTRAL POOL Heat Pump has a sound power level of 66 dB(A) at 1 metre distance. The following factors should be taken into account when working out where to locate the Heat Pump.

Determining Distance to Neighbour's Boundary

$$\boxed{6 \text{ db(A)}} - \boxed{\text{Barrier Factor}} + \boxed{\text{Reflection Factor}} = \boxed{\text{Distance Factor}}$$

Box 1                      Box 2                      Box 3

**Barrier:** A fence or barrier can reduce the level of the Heat Pump's noise heard in neighbouring premises. To do this, the barrier or fence needs to be continuous with few or no gaps and go down to ground level. It must also prevent the Heat Pump from being seen from noise sensitive locations on neighbouring premises. Noise sensitive locations include bedroom and living room windows (including second storey dwellings) and outdoor entertaining/relaxing areas.

### **Factor for Box 1**

Carefully read through the fence/barrier descriptions below. Select a value that corresponds to the fence/barrier description applicable to your situation. Put this value in Box 2 above.

Description	Value for Box 1
-------------	-----------------

1	The fence/barrier does not prevent the Heat Pump from being seen from noise sensitive locations on neighbouring properties	0
2	The fence/barrier blocks line of sight but is made of material having large gaps, such as a picket fence, or brick wall with openings or fancy inserts.	0
3	The fence/barrier blocks line of sight of the Heat Pump from noise sensitive location eg: Typical paling fence with small gaps due to warping.	5
4	The fence/barrier blocks line of sight of the Heat Pump from noise sensitive location e.g. "Colorbond" fencing, concrete block/masonry/brick, Fibre cement sheeting	10

**Reflection Factor**

Noise can reflect from walls, roofs, sheds etc. This can have the effect of making the noise seem louder than what it is. Put the corresponding value in Box 3.

**Factor for Box 2**

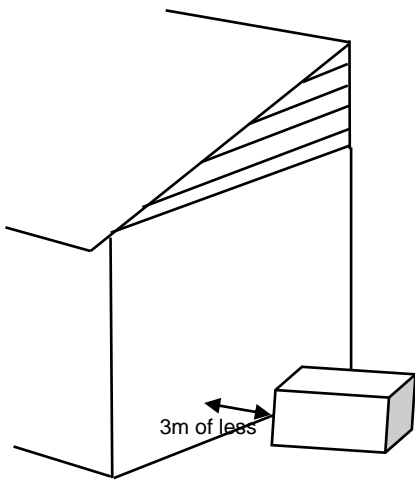

**One Reflective Surface  
Value for Box 3 = 3**

**2 reflective surfaces  
Value for Box 3 = 6**

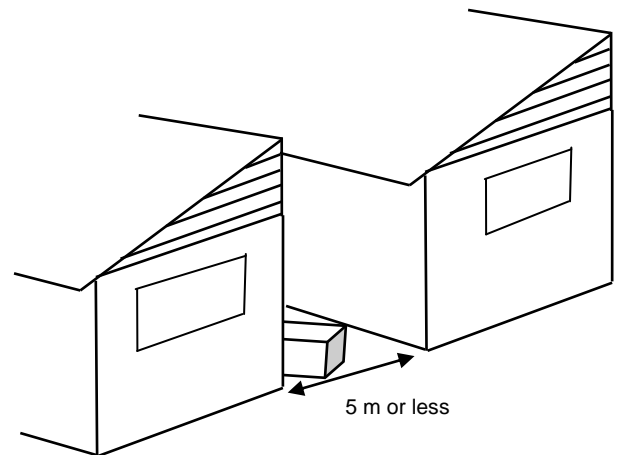
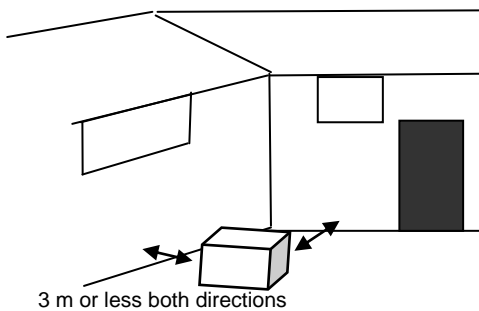

**Distance Factor**

An example may look like this:

A Timber Paling fence that goes right to the ground with some small gaps due to age, is worth a barrier factor of 5.

One reflective surface adjacent to the Heat Pump is worth a factor of 3.

The ASTRAL POOL Heat Pump has a sound power level of 66 db(A).

Therefore your equation will now look like this:

$$\begin{array}{ccccccc}
 60 \text{ {db(A)}} & - & 5 & + & 3 & = & 58 \\
 \text{Heat Pump Sound} & & \text{Barrier Factor} & & \text{Reflective Surface} & & \text{Distance Factor} \\
 \text{Pressure Level} & & & & \text{Factor} & & 
 \end{array}$$

The distance factor is 58 which should be written in Box 3.

The final step is to mark 64 on Column 2 below and draw a straight line through the middle X to reach Column 1. Column 1 is the minimum distance the Heat Pump should be installed from a noise sensitive area in your neighbour's residence.

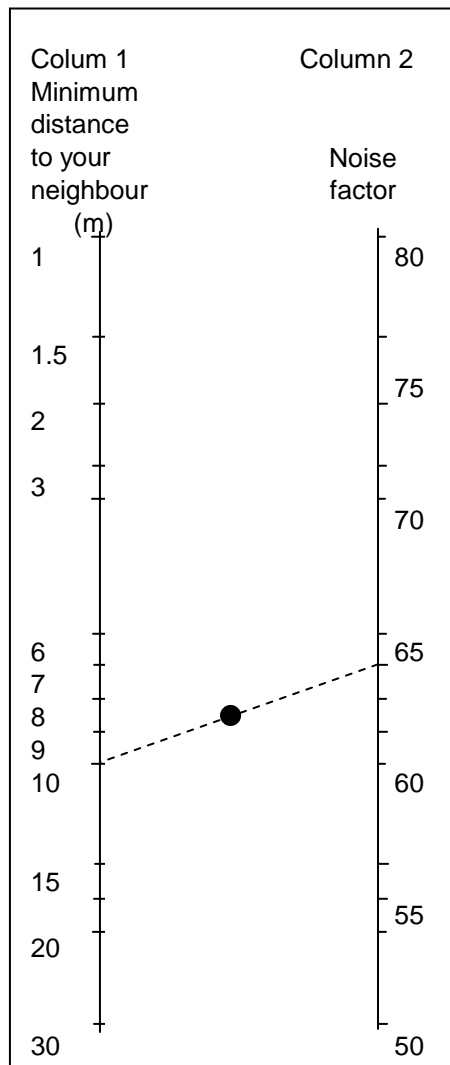

With one reflective surface and a timber paling fence with small gaps, the Heat Pump needs to be installed at least 10 metres from a noise sensitive area in your neighbour's property.

This calculation is intended as a guide only and no warranty is made or implied by Astral Pool as to its accuracy. Please consult an Acoustical Consultant or phone your Astral Pool branch office if in any doubt.

## Further Guidelines for installation of Heat Pumps

- ASTRAL POOL Heat Pumps must be installed outdoors – never install inside a plant room, garage etc.
- Allow a minimum of 500mm clearance from the sides and rear of the heat pump and a minimum of 1000mm service access from the front of the Heat Pump.
- Ensure an electrical isolation switch is located nearby the Heat Pump.
- On Three Phase models, ensure the phase rotation of the compressor is checked before commissioning of the unit.
- Ensure the water pressure switch operation is checked at least 6 times prior to handing over the Heat Pump.
- Refer to Installation and Operating Instructions for full installation, commissioning and operating procedures.



## TROUBLESHOOTING

### **HEATER WILL NOT START**

<b>Possible cause</b>	<b>Remedy</b>
Automatic control system fails	Check if power to heater is turned on and pump is in operation
Pump not running	Start pump
Pump airlocked	Check for leaks, check non return valve
Filter dirty	Clean filter
Pump strainer basket clogged	Clean strainer
Defective heater control	Shut off electrical supply and call for service
Thermostat turned off	Turn on and set to correct setpoint
Set temperature lower than water temperature	Increase set temperature (to heat)
Set temperature higher than water temperature	Decrease set temperature (to cool)
Water too hot-fault condition displayed	Refer to fault indication table

### **HEATER SHORT CYCLING (RAPID ON AND OFF OPERATION)**

<b>Possible cause</b>	<b>Remedy</b>
Insufficient water flow	Clean filter and pump strainer
Defective wiring	Repair or replace wiring
Defective high limit or thermostat	Repair or replace

If the heater cannot be made to perform correctly, please contact the Astral Pool office closest to you, your equipment installer or Astral Pool Service on 1300 727 116 local call cost.

For   VIC:            Phone (03) 9765 9700  
       NSW:            Phone (02) 9853 2100  
       QLD:            Phone (07) 3308 5400  
       GC:             Phone (07) 5552 2600  
       SA:             Phone (08) 8349 2500  
       WA:             Phone (08) 9350 2600

For all other areas, please contact our Victorian sales office.

**WIRING DIAGRAMS**

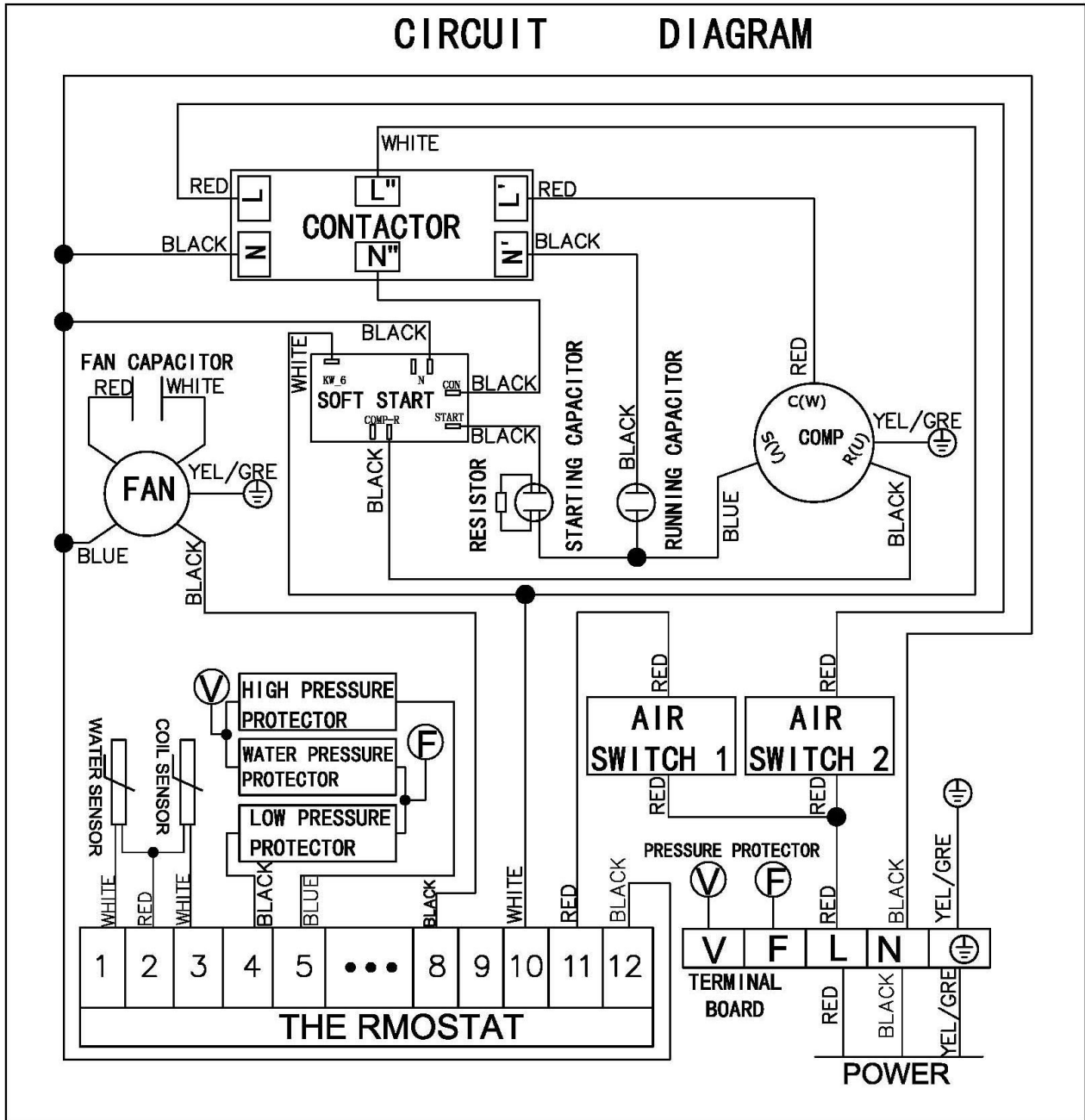

**BPM400 BPM600**

**WIRING DIAGRAMS**

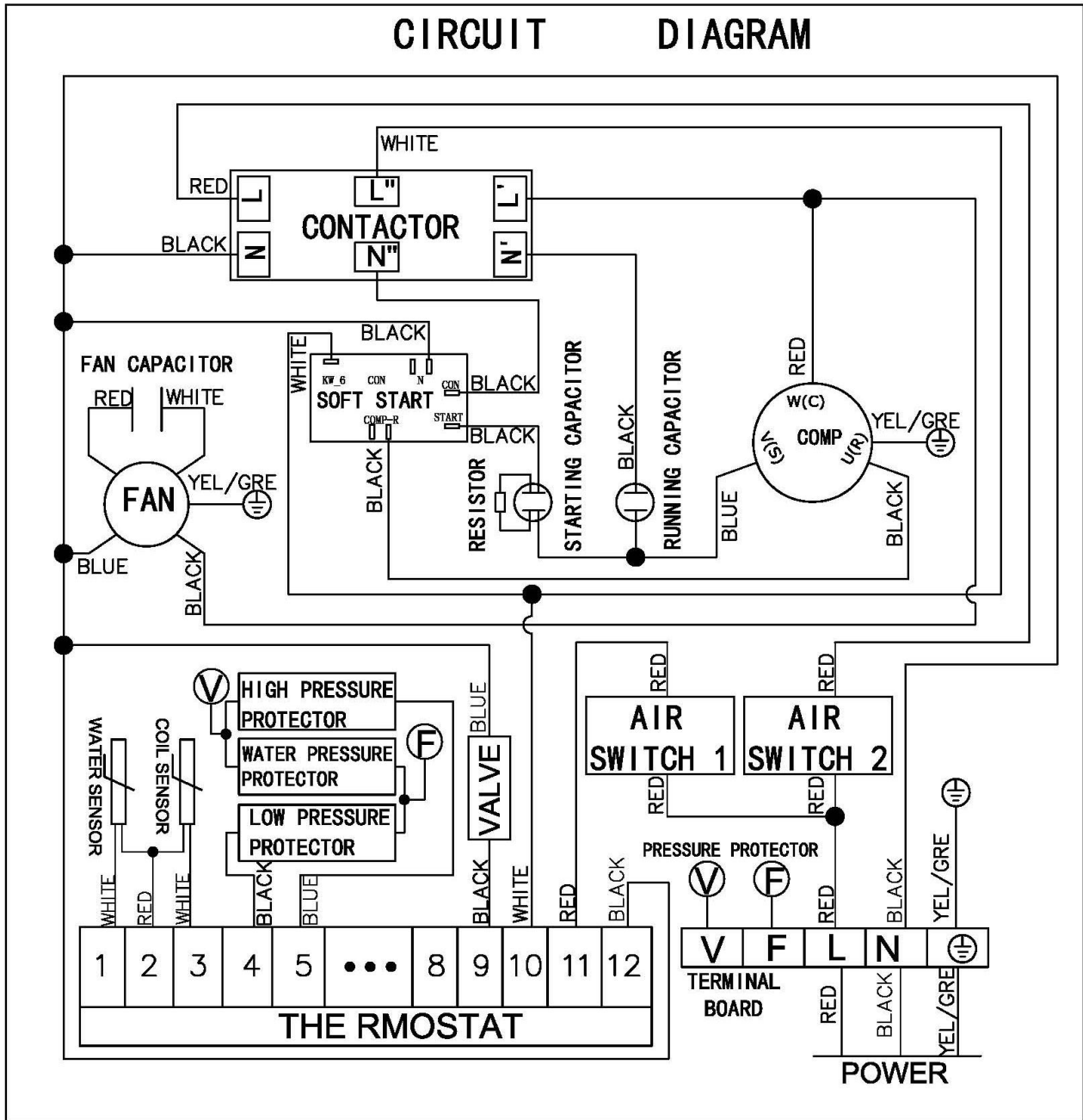

**BPM700    BPM800**

# WIRING DIAGRAMS

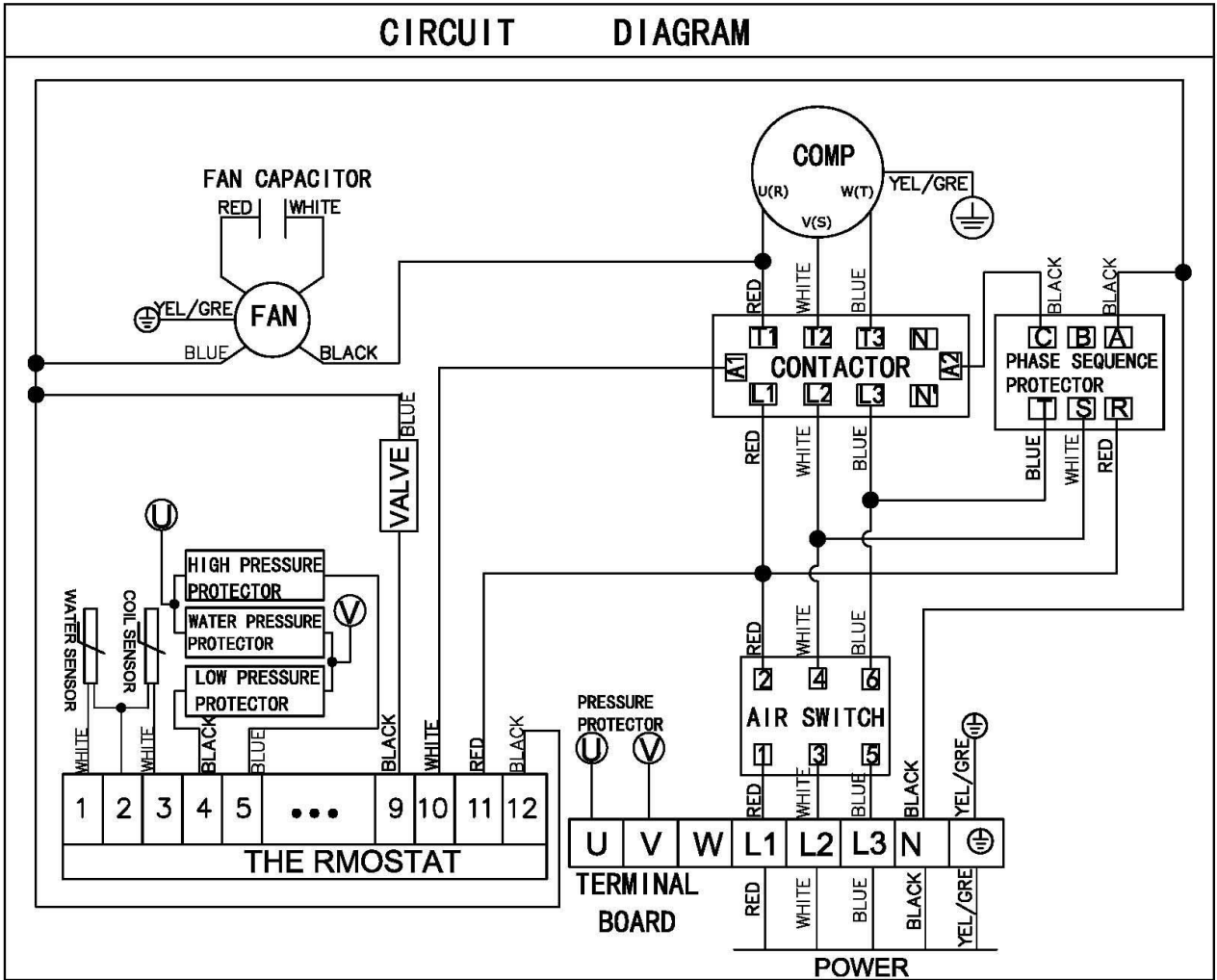

BPT900

## **WARRANTY**

AstralPool Australia Pty Ltd (ABN 97 007 284 504) ("AstralPool") provides the following warranty in relation to its BP Series Heat Pumps ("Product").

*Our goods come with guarantees that cannot be excluded under the Australian Consumer Law. You are entitled to a replacement or refund for a major failure and for compensation for any other reasonably foreseeable loss or damage. You are also entitled to have the goods repaired or replaced if the goods fail to be of acceptable quality and the failure does not amount to a major failure.*

The benefits of this warranty are in addition to any rights and remedies imposed by Australian State and Federal legislation that cannot be excluded. Nothing in this warranty is to be interpreted as excluding, restricting or modifying any State or Federal legislation applicable to the supply of goods and services which cannot be excluded, restricted or modified.

### **WARRANTY**

AstralPool warrants that, subject to the exclusions and limitations below, the Product will be free from defects in materials and workmanship during the warranty period. The warranty periods are set out below and commence 30 days after the date of purchase (to allow for installation). The warranty period may vary for different parts of the Product.

<b>Parts</b>	<b>Warranty Period</b>
Titanium heat exchange	10 years
Compressor and evaporator	3 years
Thermostat, switches and all other components	12 months

If a defect appears in the Product before the end of the warranty period and AstralPool finds the Product to be defective in materials or workmanship, AstralPool will, in its sole discretion, either:

- (a) replace or repair the Product or the defective part of the Product free of charge; or
- (b) Cause the Product or the defective part of the Product to be replaced or repaired by an Authorised AstralPool Service Agent free of charge.

AstralPool reserves the right to replace defective parts of the Product with parts and components of similar quality, grade and composition where an identical part or component is not available.

Goods presented for repair may be replaced by refurbished goods of the same type rather than being repaired. Refurbished parts may be used to repair the goods.

### **WARRANTY CLAIMS**

1. If a fault covered by warranty occurs, the customer must first contact AstralPool at the contact address listed below, or an Authorised AstralPool Service Agent.
2. Any warranty claim must be accompanied by:
  - (a) proof of purchase;
  - (b) full details of the alleged defect; and
  - (c) appropriate documentation (such as historical and maintenance records).
3. The customer must make the Product available to AstralPool or its Authorised AstralPool Service Agent for inspection and testing. AstralPool or its Authorised AstralPool Service Agent will attend the premises where the Product is installed for inspection and testing. If the Product is installed:
  - (a) outside a capital city metropolitan area; and
  - (b) is not within a 20 km radius of an Authorised AstralPool Service Agent;then the customer may have to pay a travel fee.

4. If such inspection and testing finds no defect in the Product, the customer must pay AstralPool's usual costs of service work and testing. If such inspection and testing finds a defect that is not covered by this warranty, the customer must pay AstralPool's usual costs of service work plus any parts and labour required to repair the Product, unless recoverable from AstralPool on the failure of any statutory guarantee under the ACL.

### **Exclusions**

The warranty will not apply where:

- (a) the customer is in breach of the Terms and Conditions of Sale;
- (b) the Product was used for a purpose other than one it was intended for;
- (c) the Product was repaired, modified or altered by any person other than AstralPool;
- (d) the Product has not been installed, maintained and/or operated in complete compliance with the installation and operating instructions and any instructions by AstralPool;
- (e) the Product has been subject to accident, negligence, alteration, abuse or misuse.

The warranty does not extend to:

- a) normal wear and tear;
- b) weather and other environmental conditions including but not limited to storm, flood, and/or heat wave damage; or
- c) service and maintenance items.

Examples of exclusions include but are not limited to:

- incorrect water chemistry
- incorrect power supply / connection

### **Commercial Installations**

On commercial installations, such as health clubs, motels/hotels and hydrotherapy facilities, the warranty is limited to parts and in field labour (within capital city metropolitan areas or 20 km radius of Authorised AstralPool Service Agents) for a period of 12 months from the date of purchase plus 30 days to allow for installation.

### **LIMITATIONS**

AstralPool makes no express warranties or representations other than set out in this warranty.

The repair or replacement of the Product or part of the Product is the absolute limit of AstralPool's liability under this express warranty.



ASTRALPOOL Pty. Limited. A.B.N. 97 007 284 504  
www.astralpool.com.au email: service@astralpool.com.au  
Information and specifications subject to change without notice.

<b>Victoria:</b>	<b>New South Wales:</b>	<b>Queensland:</b>	<b>South Australia:</b>	<b>Western Australia:</b>	<b>Gold Coast:</b>	<b>Townsville:</b>
Ph: (03) 8796 8600	Ph: (02) 9853 2100	Ph: (07) 3308 5400	Ph: (08) 8152 7600	Ph: (08) 9350 2600	Ph: (07) 5552 2600	Ph: (07) 4750 3100
Fax: (03) 8796 8670	Fax: (02) 98532170	Fax: (07) 3308 5470	Fax: (08) 81527670	Fax: (08) 9350 2670	Fax: (07) 5552 2670	Fax: (07) 4750 3170